

OPERATION MANUAL



POWERLINE
TMZ SERIES ROTARY TILLERS
(TMZ150-5 & TMZ180-6)

TMZ model rotary tiller (Gear drive) .

The 3 point linkage of TMZ150-TMZ180 model can be moved by adjust the screws.

Model	Working width (cm)	Blades shaft speed (rpm)	Number of blades	Tilling depth (cm)	Fitted power (hp)	Net weight (kg)	Gross weight (kg)
TMZ-150-5	150	192	32	8-14	35-40	269	309
TMZ-180-6	180	192	36	8-14	50-55	288	348

Packaging: wooden-crate kickstand

Package size: (cm*cm*cm)

TMZ-150 175*73*73

TMZ-180 205*73*73

I. GUARANTEE

Materials made by us have are guaranteed to have no defects following manufacture. This guarantee is effective for 12 months following the invoice date and will not affect your statutory rights.

Exceptions:-

(1) The guarantee will be void if:-

- a. The correct care and maintenance is not observed.
- b. The machine is misused or used for a purpose other than described in part (2) .
- c. The machine is changed, incorrectly mounted or fitted to a power source unsuitable for the purpose the machine is intended for.

(2) The rototiller is intended for the cultivation of soft soils or previously prepared soils suitable for rotovating.

(3) The technical service is available for the identification and replacement of defective parts. The defective parts should be returned to the seller with an attached description of the defects. The guarantee or terms of supply will dictate the guarantee available to you. However, in most cases this will be limited to replacing the parts and not provide compensation for labor costs for the work involved.

(4) The guarantee is strictly limited to the purchaser of the machine. Any unauthorized work by the purchaser or a 3rd party without the written consent of the seller will immediately render the guarantee null and void.

(5) Our obligation is limited of the above written guarantee terms. The purchaser expressly agrees to our terms and will return the machine unused if any of the terms are not acceptable.

(6) All goods remain the property of the seller until the goods are paid for. Full title of the goods will not pass to the purchaser until verified funds are cleared and the seller has confirmed the banking process is complete.

(8) Neither party shall be liable in damages or have the right to terminate this Agreement for any delay or default in performing hereunder if such delay or default is caused by conditions beyond its control including, but not limited to Acts of God, Government restrictions (including the denial or cancellation of any export or other necessary license), wars, insurrections and/or any other cause beyond the reasonable control of the party whose performance is affected.

(9) Neither party shall be liable for any failure or delay in performance under this Agreement (other than for delay in the payment of money due and payable hereunder) to the extent said failures or delays are proximately caused (I) by causes beyond that party's reasonable control and occurring without its fault or negligence, including, without limitation, failure of suppliers, subcontractors, and carriers, or party to substantially meet its performance obligations under this Agreement, provided that, as a condition to the claim of non-liability, the party experiencing the difficulty shall give the other prompt written notice, with full details following the occurrence of the cause relied upon. Dates by which performance obligations are scheduled to be met will be extended for a period of time equal to the time lost due to any delay so caused.

10) Licensor's failure to perform any term or condition of this Agreement as a result of conditions beyond its control such as, but not limited to, war, strikes, fires, floods, acts of God, governmental restrictions, power failures, or damage or destruction of any network facilities or servers, shall not be deemed a breach of this Agreement

II ROTATING BLADES

This symbol means possible danger to you, so please pay attention to this symbol and the possible hazards it represents.

III PREVENTIVE STEPS FOR ACCIDENT

During operation, you should always observe the correct operating procedures and the safety rules applicable. Make sure you are fully conversant with the methodology and risk assessments before commencing operations.



The following basic safety rules are intended to assist you to avoid danger. They are not intended to replace your company safety rules or methodology required before commencing operation of the machine.



(1) General care and maintenance: Stop the tractor, disengage the PTO drive and ensure the blades have ceased to rotate before commencing any work on the rototiller.

(2) Before first use: Ensure all nuts and bolts are correctly tightened. Particular attention should be given to the cutting blade bolt tightness.

(3) Ensure the carded shaft is restricted from turning by the use of the supplied chains. After the operation is finished, the cardan shaft should be checked for signs of wear and be replaced as required.



(4) Before and during operation, you must ensure the work area is clear of personnel. Small stones can be ejected and cause injury during the rotovating process.



(6) Always ensure the tractor is correctly manned with trained personnel. Unauthorized operators are strictly prohibited from operating this machine.

(7) During maintenance or repair, a proper safety procedure should be implemented such as the key removal from the tractor. Make sure the tractor cannot inadvertently move to avoid damage to the maintainer



(8) Do not wear loose clothing or clothing which may become entangled in the blades of the machine.

(9) Only original manufacturers parts may be fitted to this machine or the guarantee will be void.



IV OPERATION & TRAVEL

1. Before using, ensure you are fully compliant with the safe operation of the machine and you have read and understood the manual.
2. After 10 hours of operation, ensure all nuts and bolts are re-checked for tightness. Check oil levels and any signs of oil loss.
3. Before operation, the tractor must have the right speed output of 540rpm to avoid damaging the machine.
4. The operating speed is 1.2-1.5 km/h. Any deviation will cause irreparable damage and void your warranty.

VII CUTTING TOOL REPLACING

1. Before changing the cutting blades, stop the engine of the tractor, and after all moving parts have stopped, disconnect the PTO shaft.
2. Check the condition of each blade by carefully rotating the shaft. screw down all the bolts(1), replace used or damaged cutting tools and bolts making sure of the correct orientation of the blades, install left and right(4) blades carefully, tighten bolts(1) with shim(2) (If required) and nut (3), and tighten bolt(1).

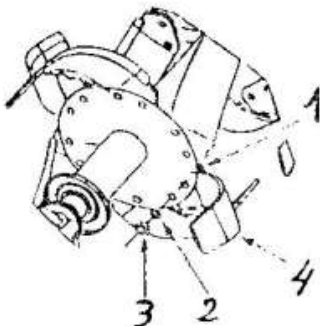

3. For best performance of the implement, use the original cutting tools only.

IX INFORMATION SYMBOLS

1. Label No. 1 means the model.
2. Check the oil levels carefully. Depending on the specification of your supplier the machine can be delivered with or without engine oil.
3. Read operation instruction carefully before using.
4. Output power is 540rpm.

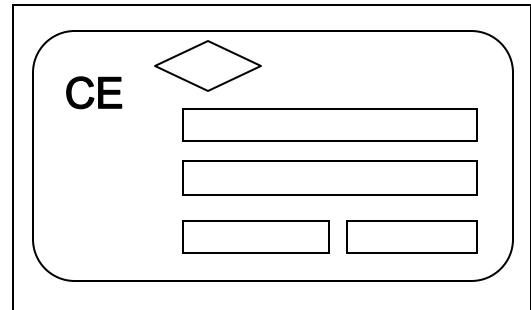

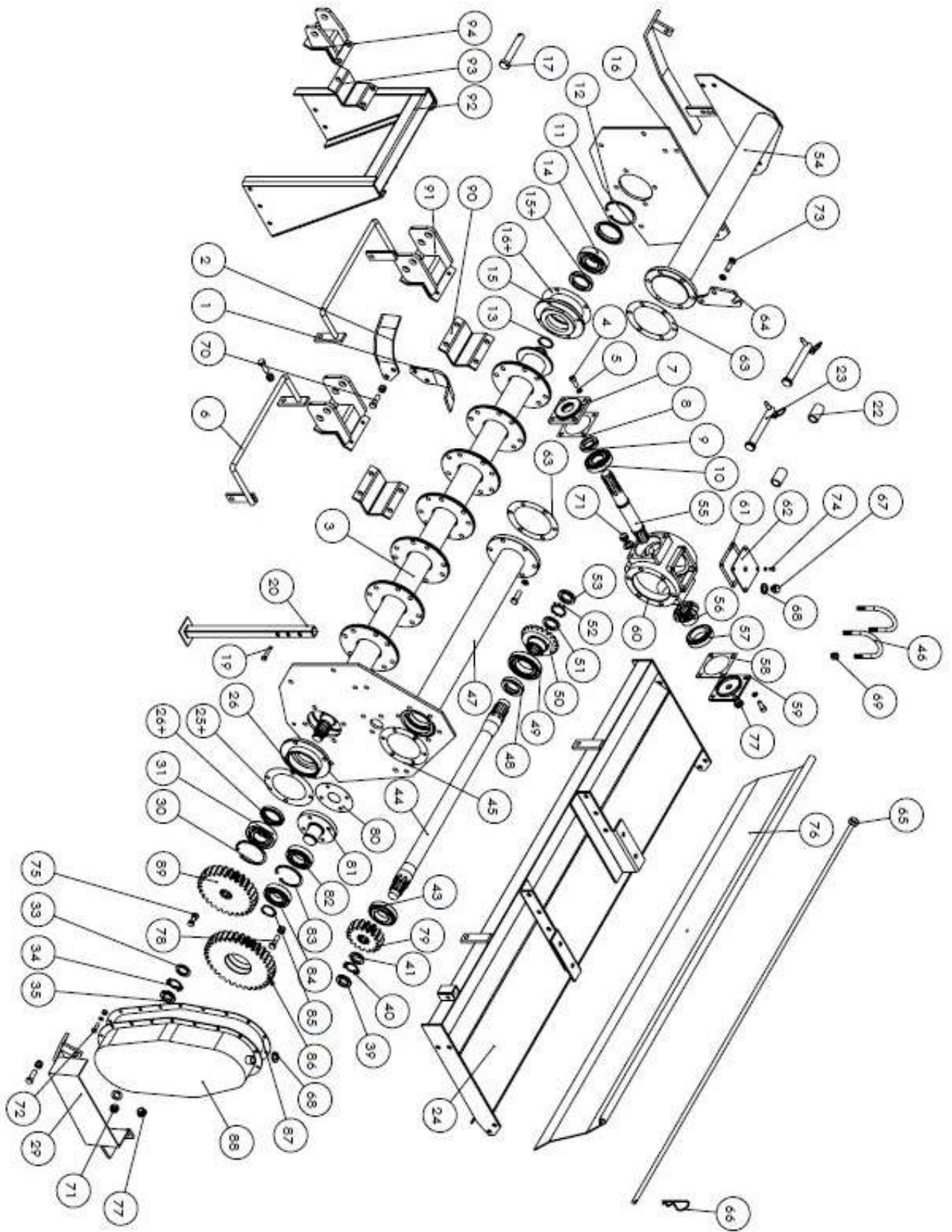

TMZ Spare Parts List

No.	Name	Qty	No.	Name	Qty
1	Left-bent blade	16	46	U-bolts	2
2	Right-bent blade	16	47	Main frame pipe	1
3	Blade shaft	1	48	Oil seal	1
4	Bolts	8	49	Bearing	1
5	Spring washer	8	50	Big bevel gear	1
6	Protective guard	2	51	Washer	1
7	Cap	1	52	Stop washer	1
8	Oil seal ring	2	53	Circular nut	1
9	Oil seal	1	54	Auxiliary frame pipe	1
10	Bearing	1	55	First shaft	1
11	cover	1	56	Small bevel gear	1
12	Eyelet washer	1	57	Bearing	1
13	Shaft washer	1	58	Oil seal ring	1
14	Bearing	2	59	Cap	1
15	Bearing seat	1	60	Intermediate gearbox	1
15+	Oil seal of bearing seat	1	61	Oil seal ring	1
16	Side board	1	62	Cap	1
16+	Oil seal ring of bearing seat	1	63	Oil seal ring	2
17	Pin	1	64	Suspension Slice	1
19	Pin		65	Rod	1
20	Stay bar	1	66	B type pin	1
21	Pin	1	67	Venting oil plug	2
22	Sheath	3	68	Copper gasket	2
23	Pin	2	69	M12 locknut	1
24	Cover	2	70	M12*30 bolt+locknut	
25	Side board	1	71	Oil drain plug	2
25+	Oil seal ring of bearing seat	1	72	M8*25 bolt + nut + spring washer	16
26	Bearing seat	1	73	M12*35 bolt + spring washer	12
26+	Oil seal of bearing seat	1	74	M6*10 bolt + spring washer	4
29	Anti-friction plate	1	75	M10*35 bolt + nut + bonded washer	8
30	Eyelet washer		76	Tail plate	1
31	Bearing		77	Oil check plug	2
33	Washer	2	78	Bolt	6
34	Stop washer	1	79	Idler gear	1
35	Circular nut	1	80	Idler shaft paper washer	1
39	Circular nut		81	Idler shaft	1
40	Stop washer	1	82	Bearing208	1
41	Washer	1	83	Circlip For Hole	1
43	Bearing	1	84	Bearing208	1
44	Second shaft		85	Circlips for shaft	1
45	Oil seal ring		86	Idler gear	1
87	Paper Washer for side box	1	91	The lower suspension plate	2
88	Side gear box	1	92	Shield protective cover	1
89	driven gear	1	93	The upper suspension fixed plate	1
90	The lower suspension fixed plate	2	94	The upper suspension plate	1