

Darrell Harp Enterprises, Inc.

PO Box 140 // 819 4th Street NW

Red Bay, AL 35582

Phone: 256-356-4424 // Fax: 256-356-8300

Email: darrellh@bellsouth.net

Website: www.darrellharp.com

SAFETY OPERATOR'S MANUAL

Powerline Finishing Mowers

Model: PLFMN-120

PLFMN-150

PLFMN-180



IMPORTANT

READ THESE INSTRUCTIONS BEFORE INSTALLING AND USING
THIS IMPLEMENT

PRODUCT SPECIFICATIONS

PRODUCT NUMBER

FINISHING MOWER MODELS

PLFMN-120

PTO driven rear discharge – 3 high strength blades – 4 independent height adjustable caster wheels.

PLFMN-150

PTO driven rear discharge – 3 high strength blades – 4 independent height adjustable caster wheels.

PLFMN-180

PTO driven rear discharge – 3 high strength blades – 4 independent height adjustable caster wheels.

IMPLEMENT SPECIFICATIONS

MODEL	PLMFN-120	PLFMN-150	PLFMN-180
Tractor HP	15-25 hp	20-35 hp	30-55 hp
Three-point linkage	Cat. I	Cat. I	Cat. I
Length	4.25 ft.	4.50 ft.	5.50 ft.
Width	50 in.	62 in.	73 in.
Weight	386 lbs.	415 lbs.	463 lbs.
Cutting Width	48 in.	60 in.	72 in.
Cutting Height	1.5 – 3.5 in.	1.5 – 3.5 in.	1.5 – 3.5 in.
Number of Blades	3	3	3
Discharge	Rear	Rear	Rear
PTO	540 rpm	540 rpm	540 rpm

The finishing mowers are PTO powered with three available model sizes in category I three-point linkage from 4 to 6 foot for tractors up to 55 hp.

SAFETY INSTRUCTIONS



Before operating the finishing mower read the following safety instructions. Failure to comply with these warnings may result in serious injury or death.

CONGRATULATIONS on the purchase of your new PowerLine Finishing Mower. This information is to assist you in preparing, operating and maintaining your mower. Please read and understand the information completely before operating your mower, paying special attention to all the safety details. Keep this manual handy for a ready reference.

1.1 SAFETY FIRST

YOU are responsible for the safe operation and maintenance of your finishing mower. YOU must ensure that you and anyone else who is going to operate, maintain or work around the finishing mower is familiar with the operating and maintenance procedures and related SAFETY information contained in this manual. This manual will take you step-by-step through your working day and alert you to all good safety practices that should be adhered to while operating the finishing mower.

Remember, YOU are the key to safety. Good safety practices not only protect you but also the people around you. Make these practices a working part of your safety program. Be certain that EVERYONE operating this equipment is familiar with the recommended operating and maintenance procedures and follows all the safety precautions. Most accidents can be prevented. Do not risk injury or death by ignoring good safety precautions.

1. Finishing mower owners must give operating instructions to operators or employees before allowing them to operate the machine.
2. The most important safety feature on this equipment is a SAFE operator. It is the operator's responsibility to read and understand ALL safety and operating instructions in the manual and to follow them. Accidents can be avoided.
3. A person who has not read and understood all operating and safety instructions is not qualified to operate the machine. An untrained operator jeopardizes themselves and bystanders to possible serious injury or death.
4. Do not modify the equipment in any way. Unauthorized modification may weaken the function and/or safety and could affect the life of the equipment.
5. Think SAFETY! Work SAFELY!

1.2 GENERAL SAFETY

1. Read the operator's manual and all safety signs carefully before operating, maintaining, adjusting or removing the finishing mower.
2. Do not allow passengers to ride on the finishing mower.
3. Operate only at safe distances from bystanders. Clear the area of people, especially small children, before starting.
4. Stop PTO before dismounting tractor.
5. Keep feet and hands from under the finishing mower at all times.

SAFETY INSTRUCTIONS

6. Keep all shields in place. If shield removal becomes necessary for repairs, replace the shield prior to use.
7. Do not stand between the tractor and the finishing mower.
8. Do not approach the finishing mower until all motion has stopped.
9. All rotary blades have the ability to discharge objects at high speeds, which could result in serious injury to bystanders or passers-by, use with extreme caution.
10. Place all controls in neutral, stop tractor engine, set parking brake, remove ignition key and wait for all moving parts to stop before servicing, adjusting, repairing, attaching or removing.
11. Review safety related items annually with all personnel who will operate or maintain the finishing mower.
12. Do not operate machine if you feel unwell or physically unfit, in which case you should stop working.
13. This machine was designed with safety very much in mind. However, there is no real substitute for caution and attention in preventing accidents. Once an accident has happened, it is too late to think about what you should have done.
14. Use a tractor equipped with Roll Over Protective Structure (ROPS). Always wear your seatbelt. Serious injury or even death could result from falling off the tractor – particularly during a turnover when the operator could be pinned under the ROPS or the tractor.
15. Never exceed the limits of a piece of machinery. If it's ability to do a job, or to do so safely, is in question – DON'T TRY IT.
16. Clear working area of stones, branches or hidden obstacles that might be hooked or snagged, causing injury or damage.

1.3 OPERATING SAFETY

1. Read and understand the operator's manual and all safety signs before operating, servicing, adjusting, repairing or removing.
2. Do not allow riders.
3. Install and secure all guards and shields before starting or operating.
4. Keep hands, feet, hair and clothing away from moving parts.
5. Place all controls in neutral, stop tractor engine, set parking brake, remove ignition key and wait for all moving parts to stop before servicing, adjusting, repairing, attaching or removing.
6. Place all tractor and machine controls in neutral before starting.
7. Never start or operate machine unless sitting on tractor seat.
8. Clear the area of bystanders, especially small children, before starting.
9. Stay away from PTO shaft and machine when engaging PTO. Keep others away.
10. Use warning lights on tractor when transporting.
11. Do not put hands or feet under machine while tractor engine or machine is running.
12. Do not operate finishing mower in the raised position
13. Objects can be thrown out from under machine with sufficient force to severely injure people. Stay away from machine when it is running. Keep others away.
14. Always know what you are cutting. Never operate finishing mower in an area that has hidden obstacles. Remove sticks, stones, wire or other objects from working area before starting.
15. Review safety instructions with all operators annually.

SAFETY INSTRUCTIONS

1.4 STORAGE SAFETY

1. Store the machine in an area away from human activity.
2. Do not permit children to play on or around the stored machine.
3. Store the machine in a dry, level area
4. Clean grease and oil as required and protect it from the elements.

1.5 MAINTENANCE SAFETY

1. Good maintenance is your responsibility. Poor maintenance is an invitation for trouble.
2. Follow good shop practices.
3. Keep service area clean and dry.
4. Be sure electrical outlets and tools are properly grounded
5. Use adequate light for the job at hand.
6. Make sure there is plenty of ventilation. Never operate the engine in a closed building. The exhaust fumes may cause asphyxiation.
7. Before working on this machine, shut off the engine, set the brakes, and remove the ignition key.
8. Never work under equipment unless it is secured by a mechanical stand.
9. Use personal protection devices such as eye, hand and hearing protectors when performing any service or maintenance work. Use heavy gloves when handling blades.
10. Only use genuine parts for service and maintenance.
11. A fire extinguisher and first aid kit should be kept readily accessible while performing maintenance on this equipment.
12. Periodically tighten all bolts, nuts and screws and check that all pins are properly installed to ensure unit is in safe condition
13. When completing maintenance or service, make sure all safety shields and devices are installed before placing machine in service.

SAFETY INSTRUCTIONS

1.6 SAFETY & MODEL DECALS

Good safety requires that you familiarize yourself with the various safety signs and increase your SAFETY AWARENESS.

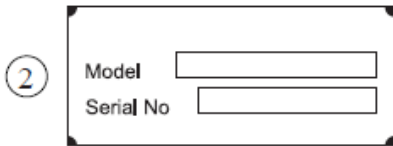

OPERATION

2.1 CHECKING BEFORE OPERATING

Before operating the machine, the following areas should be checked:

1. Check and lubricate all grease points – cutter deck, wheels and PTO shaft.
2. Use only an agricultural tractor of horsepower within limits of the machine specified.
3. Check that the machine is properly attached to the tractor. Be sure retainers are used on the mounting pins.
4. Be sure extra weights are mounted on the front of the tractor.
5. Check the oil level in the gearbox. Add as required.
6. Check that the tractor PTO shaft turns freely and that the machine driving shaft can telescope easily.
7. Check the blades. Be sure they are not damaged or broken and swing freely in their mount. Repair or replace as required.
8. Check and tighten the blade bolts.
9. Check for entangled material in all rotating parts. Remove this material.
10. Install and secure guards, doors and covers before starting.

2.2 RUNNING-IN: FIRST 10 HOURS

Although there are no operational restrictions on the finishing mower when used for the first time, it is recommended that the following mechanical items be checked:

A. After operating for ½ hour or after completing 2 acres:

1. Check and tighten all nuts, bolts and other fasteners.
2. Check that the blades are in good condition and swing freely.
3. Check the oil level in the gearbox. Add as required.
4. Check that the machine driving shaft shield turns freely.
5. Lubricate all grease points

B. After operating for 5 hours and 10 hours:

1. Repeat items 1 to 5 of Section A
2. Then go to the regular service schedule as defined in chapter 3.2.1.

2.3 EQUIPMENT MATCHING

To ensure the safe and reliable operation of the finishing mower, it is necessary to use a tractor with the correct specifications. Use the following list as a guide in selecting a tractor to use on the machine:

1. Horsepower
The power requirements range from 15 hp for light cutting in level terrain up to 55 hp in heavy cutting in rough terrain. Use a tractor appropriate for your conditions and implement model.
2. Front End Weights
It is recommended that tractor be equipped with front end weights to provide extra stability. This is particularly important if using front wheel assist tractor.

OPERATION

3. Three Point Linkage

The finishing mower is equipped with a category I & II, three-point hitch. Be sure the tractor is in the proper configuration.

4. PTO shaft

The tractor must have a 1 3/8" 6 spline 540 rpm PTO shaft to fit the driving shaft supplied with the machine. Do not use shaft adaptors or operate at any other speed.

It is not recommended that a tractor with variable speed PTO's be used on the finishing mower. Operating at speeds faster than 540 rpm will overload the cutting components and lead to early failures.

2.4 ATTACHING/REMOVING

The finishing mower should always be located on a level, dry area that is free of debris and other foreign objects.

The machine coupling is equipped with 3 pins so that the machine can be coupled with all tractors with universal coupling. Use a solid or soft top-link to allow the mower to float behind the tractor.

When attaching the machine to the tractor, follow this procedure:

1. Lower the hydraulic linkage arms using the position control.

Note: It may be necessary to add weight to the three-point hitch to lower the lift arms.

2. Back the tractor at low speed towards the finishing mower and adjust the lower links to the proper level.
3. Stop tractor, set park brake, remove ignition key and wait for all moving parts to stop before dismounting.
4. Connect the tractor's lower links with finishing mower's left and right lower suspension bracket and put pins in. Connect the top-link with finishing mower's top-link bracket and put pin in.
5. Attach the machine PTO shaft to the tractor's PTO by retracting the locking pin. Slide the universal joint over the shaft and push on the universal joint until the lock pin clicks into position. Pull on the universal joint to be sure it is locked in position.
6. Make sure that the PTO shaft telescopes easily and that the shield rotates freely.
7. Use the three-point hitch to raise the machine from the ground before moving the machine.
8. Reverse the above procedure when removing the machine from the tractor.

OPERATION

2.5 FIELD OPERATION

Lower the implement into its "float" operating mode to allow the machine and the hitch to move up and down.

1. Move the machine into the field and align the machine with the working area.
2. Adjusting the height
There are 4 sets of adjusting spacers on the wheel fork which allow the cutting height range of 1" – 3" by adjusting spacers to achieve desired height.
3. Starting machine:
 - a. Run the engine at low idle
 - b. Slowly engage the PTO clutch to start the machine
 - c. Slowly bring the engine to the rate PTO speed. Never exceed rated speed.
 - d. Lower the machine to the ground and proceed down the field.
4. Stopping machine:
 - a. Slowly decrease engine speed to low idle.
 - b. Disengage PTO clutch slowly.
5. Ground speed

Travel speed can vary between 3 and 8 mph (5 and 13 kph) depending on the grass and terrain conditions. It is the responsibility of the operator to note the condition of the job being done and set the speed to obtain a quality job and maintain control of the machine.

The speed can be increased on smooth open easy cutting.

Decrease speed if you are producing a ragged cut or leaving patches uncut.

2.6 TRANSPORTING

When transporting the machine, review and follow these instructions:

1. Be sure that the machine is securely attached to the tractor and all retainer pins are installed.
2. Be sure you have installed extra weights on the front of the tractor.
3. Be sure you are in compliance with all applicable lighting and marking regulations when transporting.
4. Be sure your machine can be seen clearly by overtaking and oncoming traffic.
5. Do not allow riders.
6. Always use hazard flashers on the tractor when transporting.

SERVICE AND MAINTENANCE

3.1 SERVICE

3.1.1 FLUIDS AND LUBRICANTS

1. Grease – Use multi-purpose lithium-based grease.
2. Gear Box Oil – Use SAE 90 Gear oil.
3. Storing Lubricants – Your machine can operate at top efficiency only if clean lubricants are used. Use clean containers to handle all lubricants. Store them in an area protected from dust, moisture and other contaminants.

3.1.2 GREASING

1. Use a hand-held grease gun for all greasing
2. Wipe frame slide clean before greasing.

3.2 MAINTENANCE

The recommended period is based on normal operating conditions. Severe or unusual conditions may require more frequent maintenance.

3.2.1 8 HOURS OR DAILY MAINTENANCE

1. Check and screw all nuts and bolts in connection parts
2. Check the oil in the gearbox. Fill up to line if necessary
3. Pump grease into each grease nipple three to five times
4. Clean the implement; remove all grass and mud.

3.2.2 SEASON MAINTENANCE

1. Check the machine as above for daily maintenance.
2. Check the oil in gearbox; replace if contaminated.
3. Check the bearings of blade spindles for wear and tear. If worn, disassemble, clean and replace them if necessary, grease as required.
4. Check the distance between bearings and gears. Adjust them if necessary.

3.2.3 ANNUAL MAINTENANCE

1. Thoroughly clean the mower of mud and grass.
2. Drain the gearbox and clean it thoroughly. Fill with new gear oil up to the dedicated oil level.
3. Check and clean blade axles. Replace oil seals and grease them.
4. Check all blades, replace them if they are worn out or damaged.
5. Repair the side skirts, return them to original technical condition. Replace damaged or broken protective devices.
6. Remove the drive shaft from the machine. Pull the PTO shaft apart. Check and replace any components that are damaged or worn. Install the PTO shaft on the machine. The PTO shaft should telescope easily and the guard should turn freely on the shaft.

SERVICE AND MAINTENANCE

	8 hrs/Daily			40 hours/Weekly			Annually		
Lubricate PTO Shaft	√			√			√		
Lubricate Caster Wheels	√			√			√		
Lubricate Blade Spindle	√			√			√		
Check Gear Box Oil Level				√			√		
Clean Machine							√		
Lubricate and Clean PTO Shaft Cover							√		

3.2.4 PTO SHAFT MAINTENANCE

The PTO shaft is designed to telescope to allow for dimensional changes as the machine goes through its operating range. A tubular guard encloses the driving components and is designed to remain stationary on a turning shaft when required. The shaft should telescope easily and the guard turn freely on the shaft at all times. Annual disassembly, cleaning and lubrication is recommended to ensure that all components function as intended. To maintain the shaft, follow this procedure:

1. Remove the shaft from the machine.
2. Pull shaft apart.
3. Use a screwdriver to pry the tabs out of the sleeves on each end. There are 3 tabs per guard.
4. Pull the shaft out of the plastic tubular guard.
5. Use a solvent to clean the male and female portions of the telescoping ends.
6. Apply a light coat of grease to each end.
7. Clean grooves on each end where the tabs are located. Clean each tab also.
8. Apply a light coat of grease to each groove.
9. Insert the shaft into its respective guard and align the slots with the groove.
10. Insert the tabs through the slots and seat in the groove.
11. Check that each guard turns freely on the shaft.
12. Assemble the shaft.
13. Check that the shaft telescopes easily
14. Replace any components that are damaged or worn.
15. Install the shaft on the machine.

3.2.5 GEARBOX MAINTENANCE

The gearbox used on the finishing mower will give many years of trouble-free service with minimal maintenance requirements. Maintain the gearbox by following this procedure:

Oil Level:

1. Remove the level plug from the rear or side of the gear box.
2. Add oil through the filler plug located on top of gearbox until oil comes out of level plug.
3. Add through the fill plug if required.
4. If gearbox has a dipstick on filler plug, then fill to indicator mark.

IMPORTANT: Check the oil level only when the unit is cold and the machine is on level ground.

SERVICE AND MAINTENANCE

3.3 STORAGE

After the season's use, the machine should be thoroughly inspected and prepared for storage. Repair or replace any worn or damaged components to prevent any unnecessary down time at the start of the next season. To ensure a long, trouble free life, follow the procedure outlined below:

1. Thoroughly wash the machine using a pressure washer to remove all dirt, mud, debris and residue.
2. Inspect the blades and rotor for damage or entangled material. Repair or replace damaged parts. Remove all entangled material.
3. Lubricate all grease nipples. Make sure that all grease cavities have been filled with grease to remove any water residue from the inside.
4. Touch up all paint nicks and scratches to prevent rusting.
5. Move to storage area.
6. Select an area that is dry, level and free of debris.
7. Unhook from tractor (see Section 2.4).
8. If the machine cannot be placed inside, cover with a waterproof tarpaulin and tie securely in place.

Store the machine in an area away from human activity. Do not allow children to play on or around the stored machine.

3.4 TROUBLESHOOTING

This finishing mower is designed to cut grass or other plants. It is a simple and reliable system that requires minimal maintenance.

In the following section, we have listed problems, causes and solution to the problems that you may encounter.

Problem & Possible Cause	Solution
Finishing mower doesn't turn Tractor clutch slips PTO shaft slips	Repair tractor PTO clutch Tighten or replace slip clutch
Poor cutting job Traveling too fast Blades dull Grooves in grass Scalping Grass being left	Slow down Sharpen blades Bent blade. Straighten or replace blade. Traveling too fast, slow down. Top-link too short, extend top-link.
Gearbox seal leaking Grease overheating	Drill 3/16" hole in oil fill plug and insert cotter pin. Hole will act as a breather and prevent pressurizing.
Vibration Out of balance	Check for bent, damaged or broken blades. Repair or replace as required.

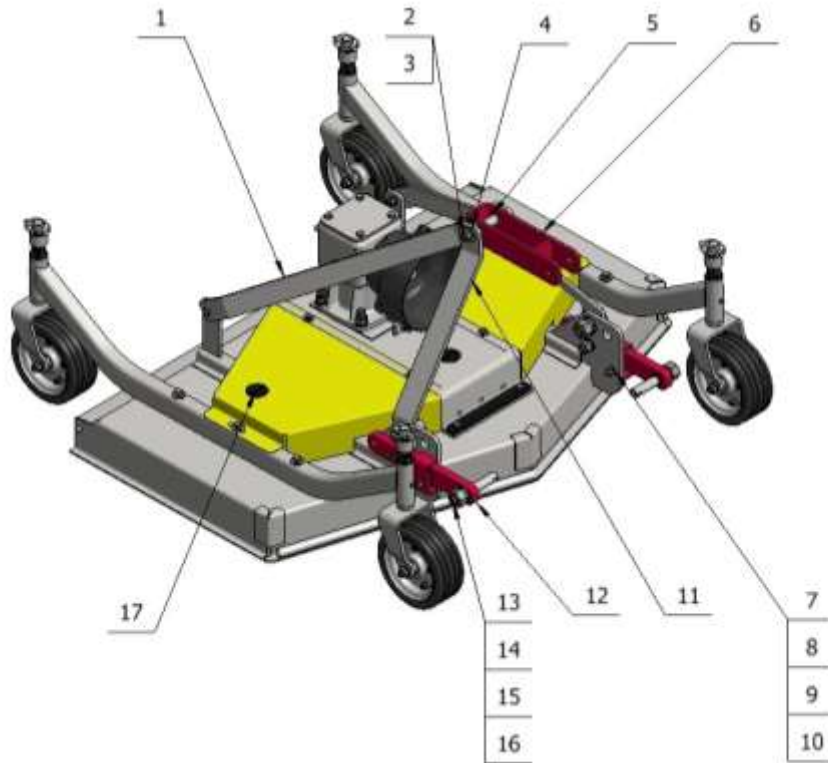

Ref. #	Part Number	Description	Qty.
1-1	FMN120.00.145	(120) pull rod	2
1-2	FMN150.00.145	(150) pull rod	2
1-3	FMN180.00.145	(180) pull rod	2
2	GB578-M12x140	M12x140 bolt	1
3	DIN985-M12	nut	1
4	GB96.1-12	washer	2
5	FMN120.00.143	Bush	1
6	FMN120.00.014	lifting bracket	1
7	GB6170-M10	M10 nut	2
8	GB93-10	10 spring washer	2
10	GB5782-M10x60	M10x60 bolt	2
11	FMN120.00.144	(120, 150, 180) bracket	2
12	FMN120.00.128	pulling rod	2
13	SL140.00.109	bolt	2
14	DIN985-M24	M24 nut	2
15	GB93-24	24 spring washer	2
16	GB97.1-24	24 plain washer	2
17	GB1152-M6	M6 grease nipple	3

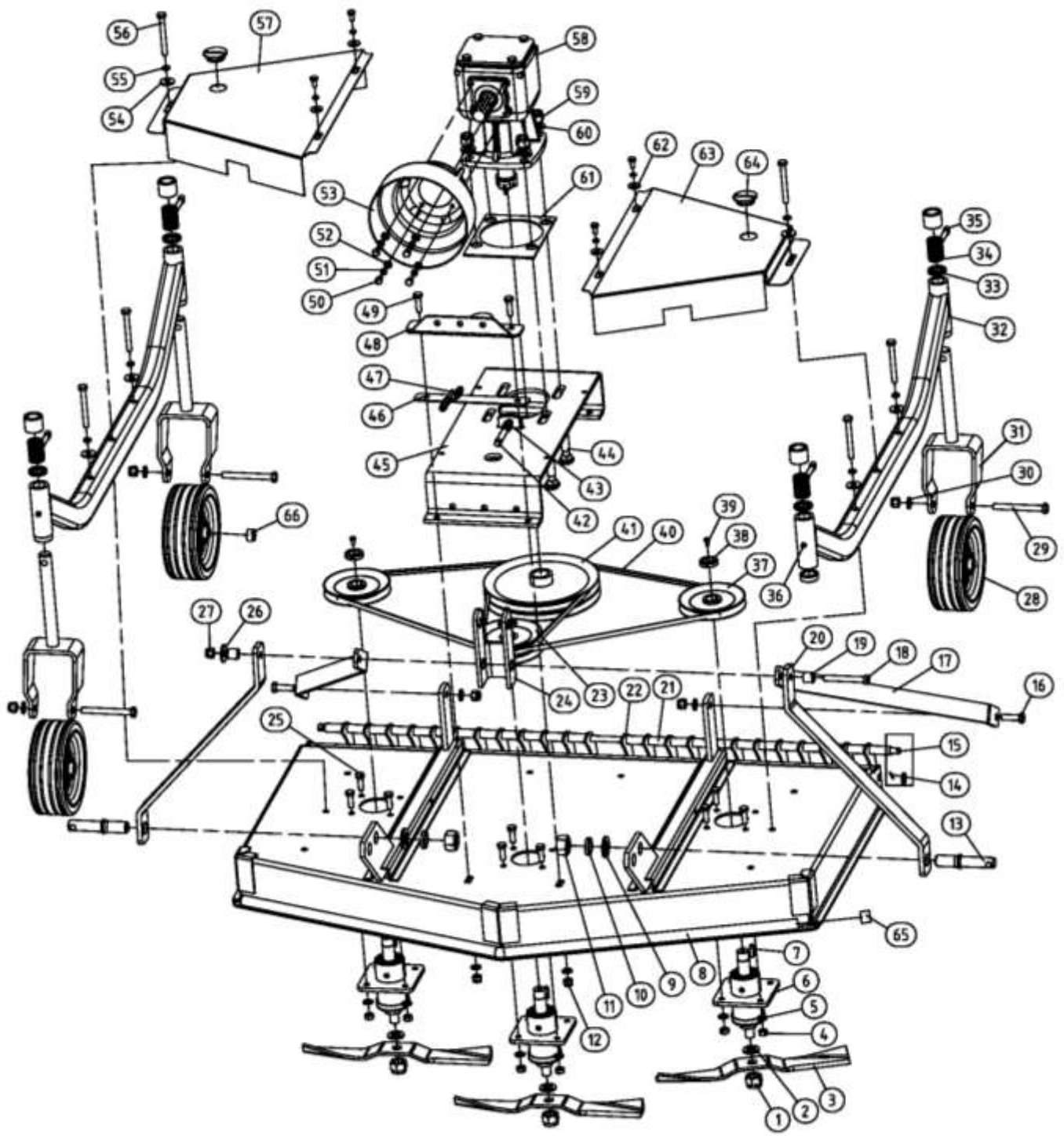

Ref. #	Part Number	Description	Qty.
1	DIN985-M18	lock nut	3
2	GB97.1-18	plain gasket	3
3-1	FM120.00.118	(120) blade	3
3-2	FM150.00.118	(150) blade	3
3-3	FM180.00.118	(180) blade	3
4	GB6170-M10	nut	12
5	GB97.1-10	plain gasket	16
6	FMN120.00.012	blade seat	3
7	GB1096-A-8x7x28	flat key	3
8-1	FMN120.00.013	hood 120	1
8-2	FMN120.00.013a	hood 150	1
8-3	FMN120.00.013b	hood 180	1
9	GB97.1-24	plain gasket	2
10	GB93-24	spring washer	2
11	GB6170-M24	nut	2
12	DIN985-M10	nut	16
13	SL140.00.109	bolt	2
14	GB91-2.5x12	cotter pin	1
15-1	FMN120.00.103	pin rod 120	1
15-2	FMN120.00.103a	pin rod 150	1
15-3	FMN120.00.103b	pin rod 180	1
16	GB5783-M12x40	screw bolt	2
17-1	FMN120.00.145	rear pull rod 120	2
17-2	FMN150.00.145	rear pull rod 150	2
17-3	FMN180.00.145	rear pull rod 180	2
18	GB5782-M12x90	half thread bolt	1
19	EF100.00.101	spacer bush	2
20	FMN120.00.144	front pull rod	2
21	FMN120.00.101	spacer bush	26
22	FMN120.00.102	shape	27
23	FM120.00.014A	double groove belt pulley	1
24	FM120.00.112	upper lifting frame	1
25	GB5783-M10x30	screw bolt	14
26	GB96.1-12	plain gasket	2
27	DIN985-M12	lock nut	7
28	FM120.00.018	pulley assembly	4
29	GB5783-M12x110	screw bolt	4
30	GB97.1-12	plain gasket	7
31	FM120.00.011	wheel fork	4
32	FMN120.00.011	pulley frame (120/150)	2
33-1	FMR120.00.115	(H=6) regulating ring	4
33-2	FMR120.00.115a	(H=12) regulating ring	4
33-3	FMR120.00.115b	(H=32) regulating ring	4
34	FM120-00-125	spring washer	4
35	200.56.011	lockpin	4
36	GB1152-M8x1	oil cup	4
37	FM120.00.013A	single groove belt pulley	2
38	FM120.00.198	M24x1.5x18 lock nut	3
39	GB5783-M6x12	screw bolt	3

Ref. #	Part Number	Description	Qty.
40-1	B1549	triangular belt (120)	2
40-2	B1753	triangular belt (150)	2
40-3	B1930	triangular belt (180)	2
41	FM120.00.012A	big belt pulley	1
42	GB85-M12x60	bolt	1
43	GB6170-M12	nut	1
44	GB12-M16X45	bolt	4
45	FMN120.00.021	transmission box frame	1
46	FMN120.00.108	rubber pad	2
47	FMN120.00.051	oil nipple	3
48	FMN120.00.107	oil nipple fixed plate	1
49	GB5783-M10X35	screw bolt	2
50	GB5783-M8x16	screw bolt	8
51	GB93-8	spring washer	8
52	GB97.1-8	plain gasket	4
53	FM120.00.199	transmission shaft cover	1
54	GB96.1-10	plain gasket	6
55	GB93-10	spring washer	6
56	GB5782-M10x90	half thread bolt	6
57-1	FM120.00.121-L	left belt pulley cover (120)	1
57-2	FM120.00.121a-L	left belt pulley cover (150)	1
57-3	FM120.00.121b-L	left belt pulley cover (180)	1
58	FM120.01.001	transmission box	1
59	DIN985-M16	nut	4
60	GB97.1-16	plain gasket	4
61	FM120.00.108	transmission box pad	1
62	GB96.1-8	plain gasket	4
63-1	FM120.00.121-R	right belt pulley cover (120)	1
63-2	FM120.00.121a-R	right belt pulley cover (150)	1
63-3	FM120.00.121b-R	right belt pulley cover (180)	1
64	FM120.00.110-2	rubber cover	3
65	FM120.00.222	plug	2
66	FM120.00.120-1	nylon cover	8

FMN120.00.012

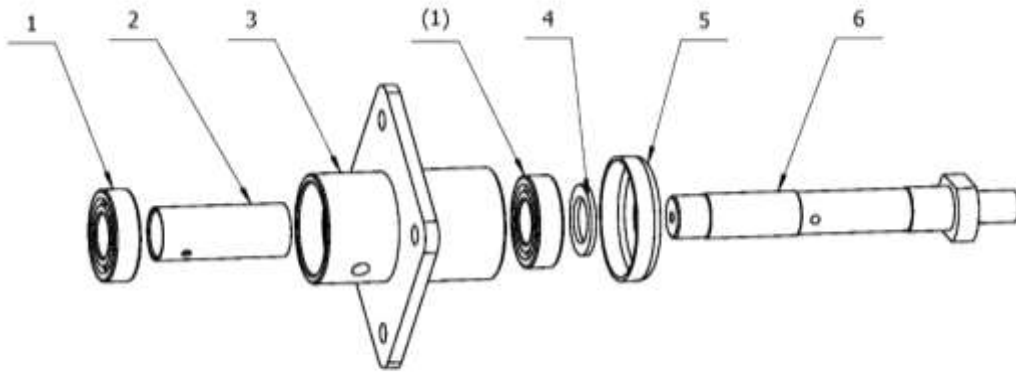

Ref. #	Part Number	Description	Qty.
1	GB276-6205-Z	deep groove ball bearing	2
2	FM120.00.114	spacer bush	1
3	FM120.00.020	blade seat	1
4	FM120.00.126	gasket	1
5	FM120.00.117	shield	1
6	FM120.00.116	blade shaft	1

FM120.00.018

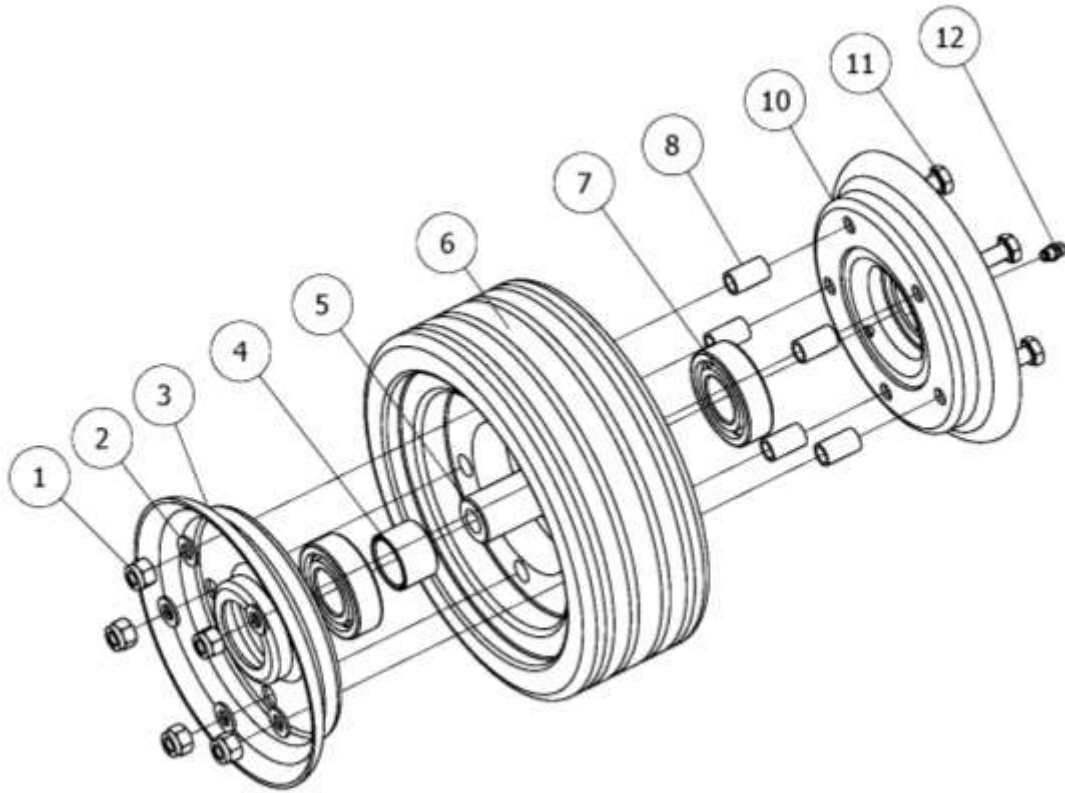

Ref. #	Part Number	Description	Qty.
1	DIN985-M8	nut	5
2	GB97.1-8	plain gasket	5
3	FM120.00.161	steel ring	1
4	FM120.00.165	spacer bush	1
5	FM120.00.166	sleeve	1
6	FM120.00.164	rubber wheel	1
7	GB276-6205-Z	deep groove ball bearing	2
8	FM120.00.162	bushing	5
9	FM120.00.161a	steel ring	1
10	GB5783-M8X35	bolt	5
11	GB1152-M6	oil cup	1
12	GB97.1-8	plain gasket	5

FM120.01.001

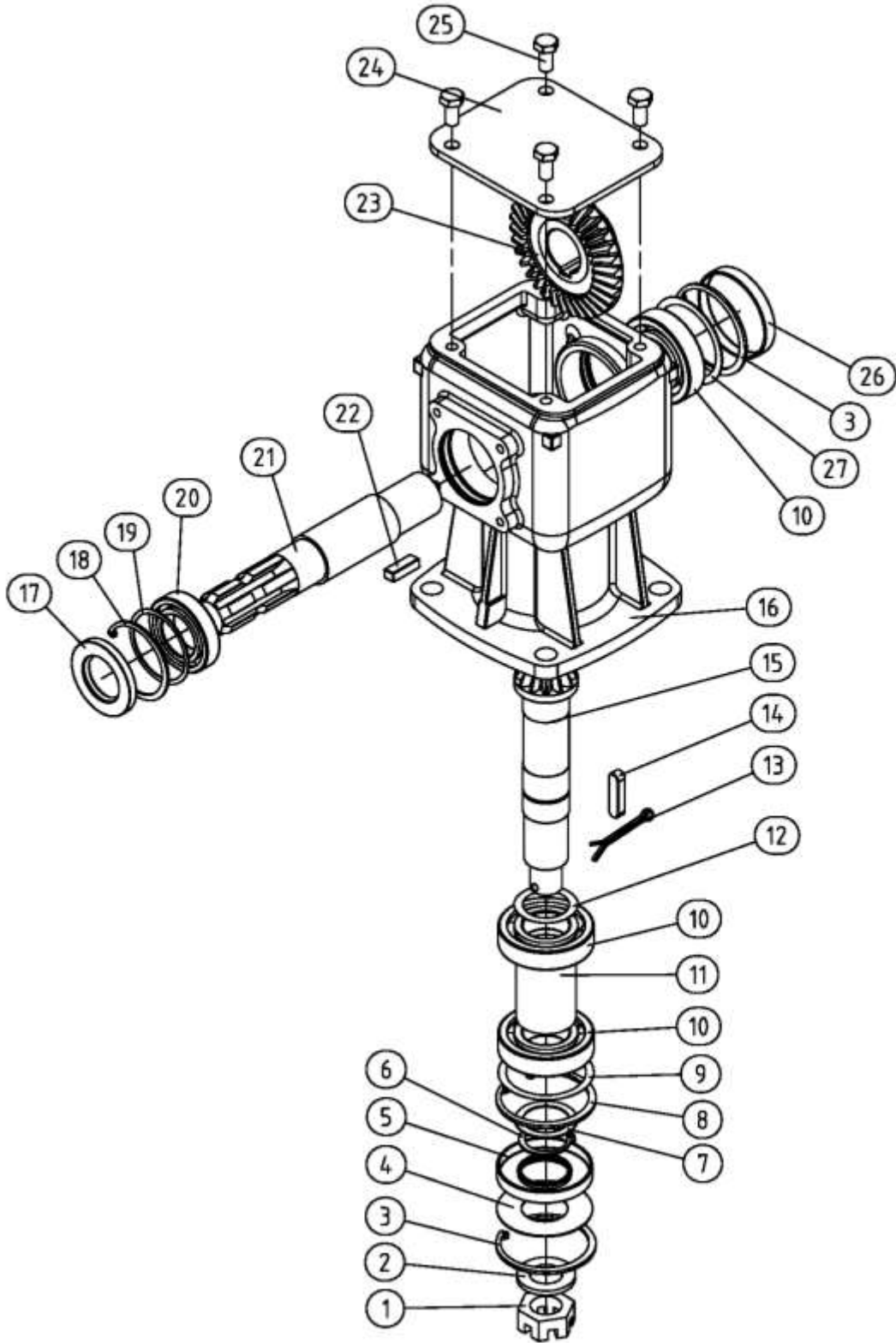

Ref. #	Part Number	Description	Qty.
1	FM120.C01	M24x2x18 nut	1
2	GB97.1-24	plain gasket	1
3	KD72x2	72x2 check ring	1
4	FM120.C03	72x35x1 board	1
5	CFW-35x72x10	FB oil seal	1
6	GB894.1-35	check ring	1
7	TZDP-48-35-1	48x35x1 adjusting shim	1
8	GB893.1-72	check ring	2
9	TZDP-72-60-0.2	72x60x0.2 adjusting pad	1
10	GB276-6207	deep groove ball bearing	3
11	FM120.C07	long sleeve	1
12	TZDP-48-35-0.2	48x35x0.2 adjusting pad	1
13	GB91-5X50	cotter pin	1
14	GB1096-A-10x8x40	flat key	1
15	FM120.C02	small gear	1
16	FM120.C04	141 box	1
17	CFW-35x62x7	FB oil seal	1
18	JB4341-62	check ring	1
19	TZDP-62-55-1	62x55x1 adjusting shim	1
20	GB276-6007	deep groove ball bearing	1
21	FM120.C08	input shaft	1
22	GB1096-A-10x8x30	flat key	1
23	FM120.C09	big gear	1
24	FM120.C10	upper cap	1
25	GB5783-M10x20	screw bolt	4
26	NFG-RCA-72x9	72x9 blanking cap	1
27	TZDP-72-60-1	72x60x1 adjusting washer	1